

TOTAL CAPACITY: 155 GALLONS

OPERATING CAPACITY: 132 GALLONS

**NOTES:**

1. SUPPORT OF BULK TANK VENT PIPING BY OTHERS
2. SCRUBBING 'WATER' SHOULD BE MAINTAINED AT OVERFLOW LEVEL FOR OPTIMUM PERFORMANCE
3. PH OF SCRUBBING 'WATER' SHOULD BE REGULARLY MONITORED & MAINTAINED FOR OPTIMUM PERFORMANCE
4. IF FUMES ARE DETECTED, CHANGEOUT OF SCRUBBING 'WATER' IS RECOMMENDED
5. LARGER & SMALLER VESSELS ARE AVAILABLE
6. VENTMASTER 155 IS AVAILABLE FROM INVENTORY FOR IMMEDIATE SHIPMENT

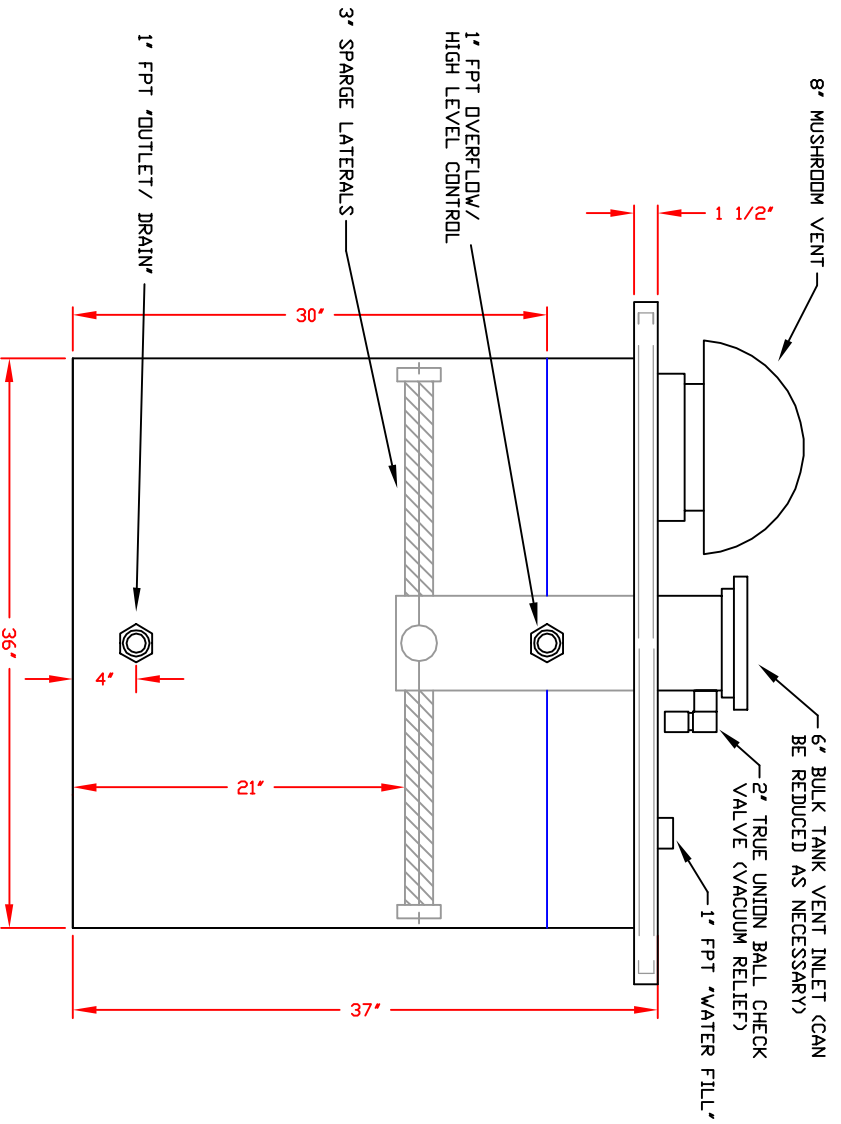

**COMMON APPLICATIONS:**

- \* HYDROCHLORIC ACID
- \* AMMONIUM HYDROXIDE/ AQUEOUS AMMONIA



TITLE	
VENTMASTER 155 FUME SCRUBBER	
SCALE: NONE	DRAWN BY: KH
DATE: 4-17-12	CHECKED BY: SI

CRP Tank Specialties, Inc. - 3300 E. 19th Street - Signal Hill, CA 90755  
 562-986-5242 - FAX 562-986-5246 - www.crp tankspecialties.com